

Low Profile Single -Piece Shower

with blue, high density polyurethane bottom

! **CAUTION: IF NOT INSTALLED PROPERLY, THE SHOWER PAN MAY NOT PERFORM AS DESIGNED AND WILL NOT BE COVERED BY THE WARRANTY.** The extremely low profile of this shower pan may eliminate the need for recessing. However, in order to get full and permanent contact with the floor, it **MUST** be installed per these instructions.

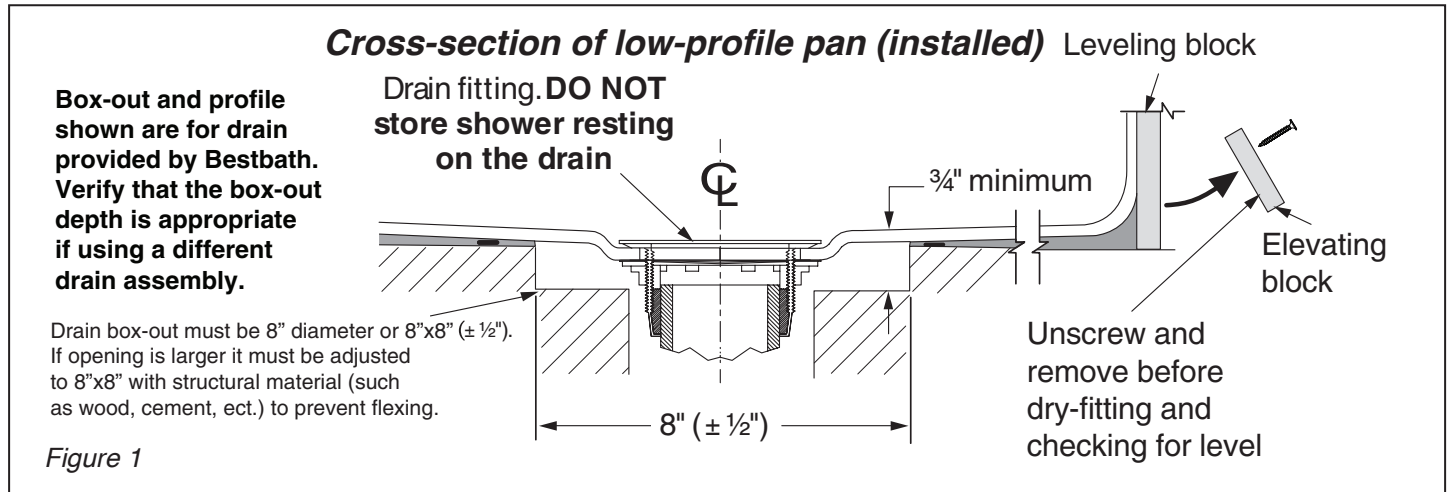

- 1 Check the shower pocket area and boxout for level and for correct dimensions. Make sure the drain hole in the floor is the correct distance from the studs and that the floor is within 1/8" of level, especially around the drain box-out. There must be no high spots and low spots should not exceed 1/8".

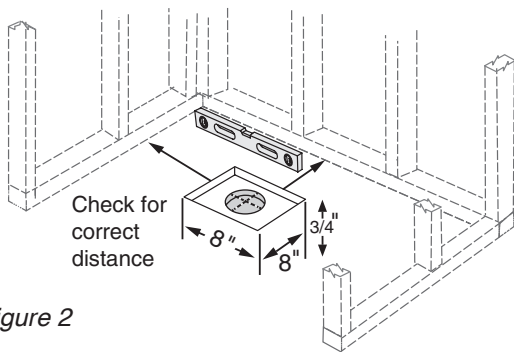

- 2 **DRY-FIT SHOWER:** Make sure you remove the elevating blocks shown in Figure 1 before proceeding. Make sure that the drain hole is centered in the 8"x8"x3/4" box-out and that it is in the correct location. Set shower in the pocket and use a level to ensure the unit is level and positioned correctly. If the unit is out of level, re-check the subfloor to ensure that it meets the required specifications.

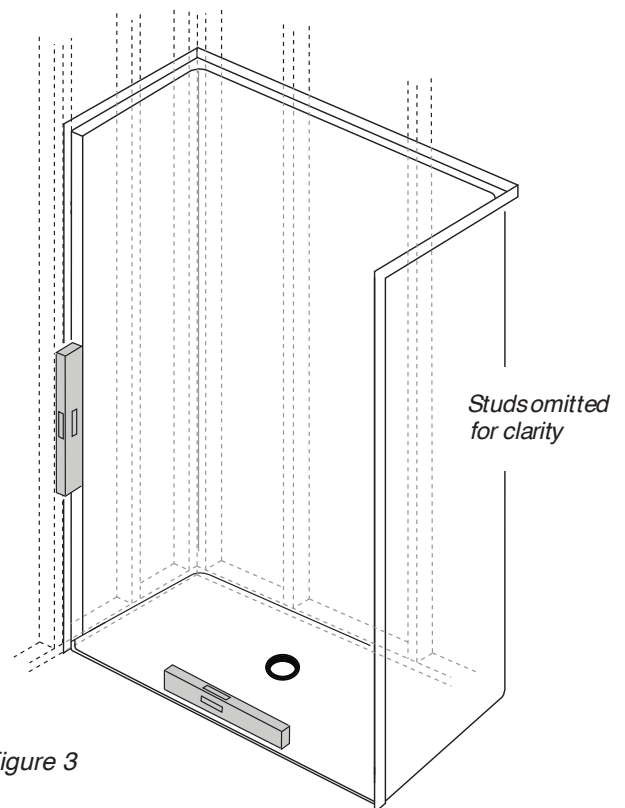

! **Drain box-out must be 8"x8"x3/4" deep.**
Drain pipe must be centered in box-out.

Low Profile Single -Piece Shower

- 3** Place a level as shown in Figure 4 and verify that there is slope towards the drain.

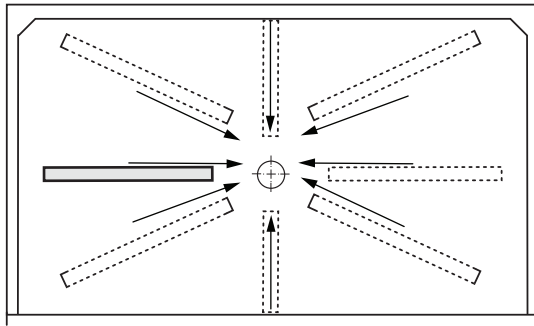

Figure 4

- 4** Once the unit is level and the slope has been verified, draw a line on the floor along the shower entry. Then, tip the unit forward, as shown. Have a plumber install the drain fitting in the shower bottom and prepare the drain pipe to receive the drain. (See steps 1-4 on page 3) **DO NOT LET THE SHOWER REST ON THE DRAIN.** This will cause the shower bottom to deform.

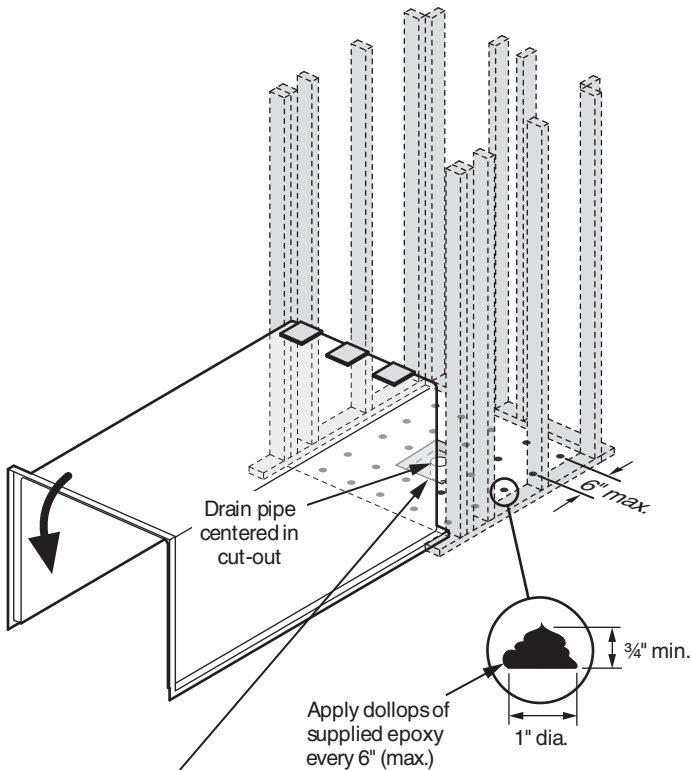

Figure 5

! Drain cut-out must be 8" diameter or 8" x 8".

- 5** Sweep the subfloor and remove all debris from the pocket area and the underside of the unit so the supplied epoxy will adhere properly. The floor may be damp, but there should be no standing water. Figure 6 shows the epoxy pattern required for installation.

Epoxy Application Pattern

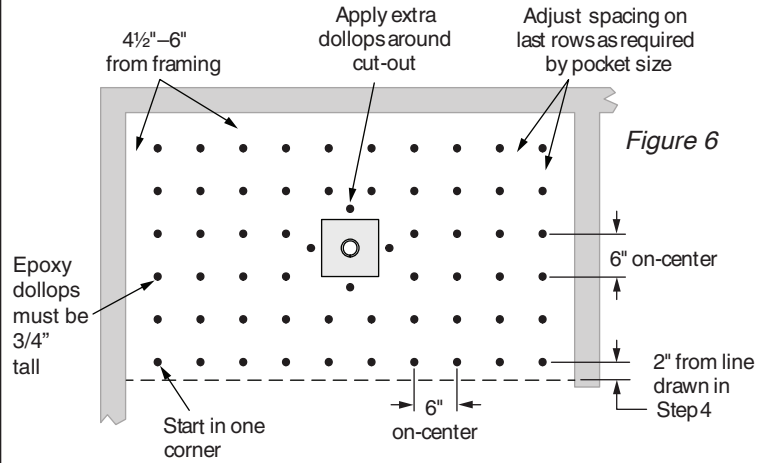

Figure 6

- 6** **TIP SHOWER UP** into position. Make sure it aligns with line drawn in Step 4. **Avoid stepping in shower until epoxy has cured.**

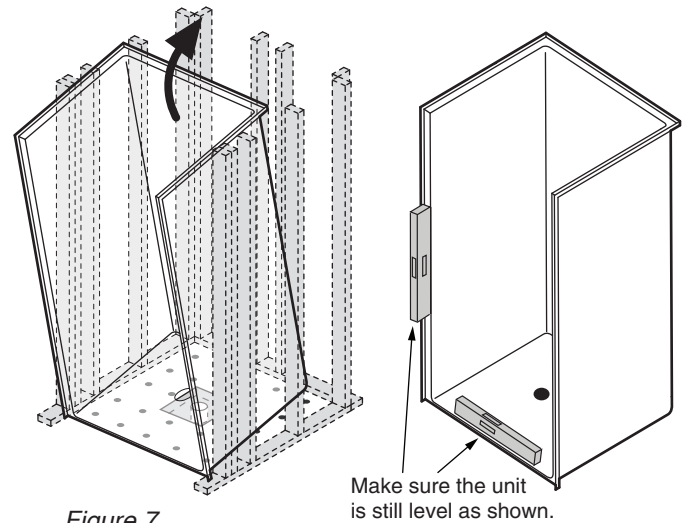
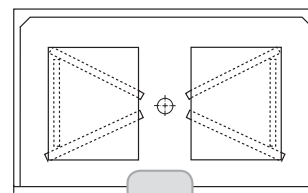

Figure 7

- 7** **POUR WATER OR CHECK THE SHOWER FLOOR WITH A LEVEL TO ENSURE PROPER DRAINAGE.** If in doubt, remove the unit and review the previous steps.

- 8** **CONSTRUCT WEIGHT PLATES** if not provided, as shown in Figure 8. Weight plates distribute the weight evenly, which helps prevent deformities in the sloping floor. They also help to ensure that the epoxy spreads evenly and bonds securely to both shower bottom and floor.

Weight plate layout for showers 5' or larger



Place an additional bag along curb

Weight plate layout for showers smaller than 5'

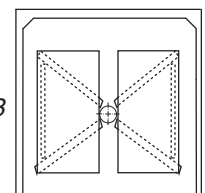

Figure 8

! **DO NOT** walk in shower until epoxy has cured.

TIP: To monitor cure time, place epoxy between two pieces of scrap wood.

Shower Installation

Drain Installation

! DO NOT walk in shower until epoxy has cured.

TIP: To monitor cure time, place epoxy between two pieces of scrap wood.

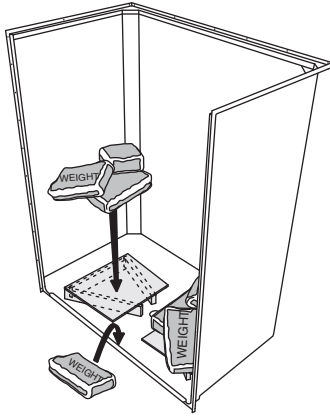

Figure 9

Weight Recommendations

An initial weight of roughly 200 pounds is required to bond the unit to the subfloor. Use a level to make sure there is slope to the drain; the level should sit flat against the shower floor (without rocking).

- 9** Monitor the cure time samples from Step 8. When the pieces of scrap wood are bonded and epoxy is hard, remove weight plates and screw flanges to framing 12" on center vertically and horizontally at each stud. Pre-drill the nailing flanges to avoid cracking the gel coat. Be sure to avoid stepping inside the shower bottom until the epoxy has fully cured.

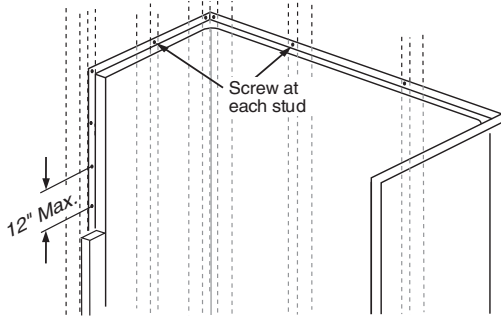
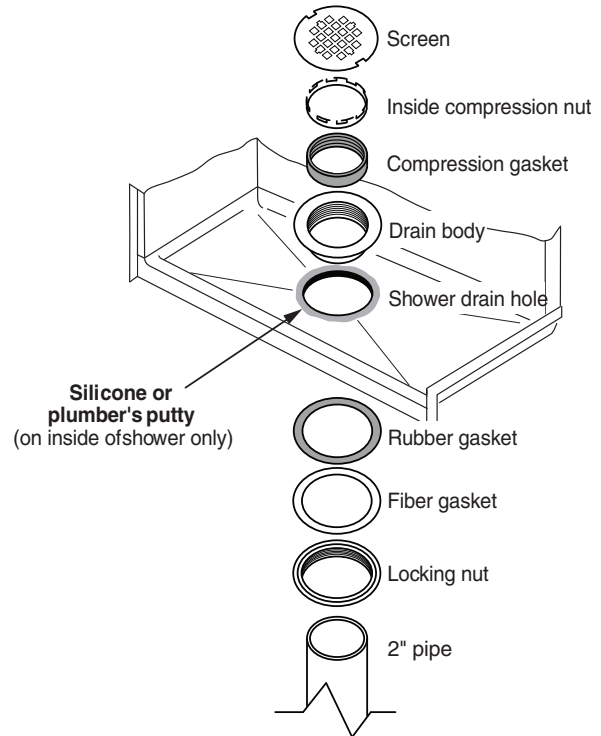

Figure 10

No-Caulk Drain Installation

- 1** Remove inside compression nut and compression gasket.
- 2** Apply silicone or plumber's putty around shower drain hole on the inside of shower only.
- 3** Install drain body in shower drain hole.
- 4** Install rubber gasket, fiber gasket and locking nut; tighten locking nut
- 5** Install shower over drain pipe (or install pipe later.)
- 6** Slide inside compression gasket into drain body and slip over pipe. **Make sure beveled end of inside compression gasket is facing up and is flush with pipe surface.**
- 7** Tighten inside compression nut into drain body using the tool provided.



Cross-section of drain (installed)

